

Cold Rooms 123x123 -18/-20 °C Built-in Unit

ITEM # _____

MODEL # _____

NAME # _____

SIS # _____

AIA # _____

102029 (CRI2F031S)

 Cold/Freezer Room
 1230x1230 th.100mm,
 included Unit 1,20 hp

Short Form Specification

Item No.

Usable volume: 3.1 m³. Panel insulation in cyclopentane (100mm thickness), with injected polyurethane foam, CFC and HCFC free. Wall and internal ceiling surfaces made of galvanized plastified steel with 120 micron nontoxic pvc coating. Internal floor in non-slip, plastic coated, galvanized steel sheet. Fast-fit centering system using new fasteners made of high resistant composite material. Rounded internal and external corners. Self-closing right-hinged door with magnetic door-gaskets; handle with lock and interior safety release. Internal lighting. Built-in refrigeration unit for operation in ambient temperatures up to +43°C. Refrigerant R452a. Defrosting through heated gas with automatic re-evaporation of defrosting water. Control panel with: ON/OFF switch, internal lighting switch and digital control with HACCP and failure alarms.

Main Features

- Very short assembly time. Expert refrigeration knowledge is not required for installation.
- Anti-slip walk-in floor.
- High hygiene standards and easy to clean thanks to rounded internal / external corners and radiused edges.
- Fast-fit centering system allows perfect alignment of the panels. These new fasteners are made of high resistant composite materials and guarantee perfect grip/sealing of all components.
- Conform to ruling European safety and hygiene standards and CE marked.
- HACCP monitoring is possible through a serial port supplied on all models.
- Equipped with internal lighting (waterproof IP54) mounted on the refrigerating unit panel.
- Floor surface on which the cold room will be placed should be levelled if presenting irregularities or unevenness up to 1 cm.
- Control panel includes: luminous ON/OFF switch, internal light switch, cold room functioning indicator, defrost cycle indicator, temperature and thermostat control with digital display.
- New vacuum injection foaming allows significant and enhanced insulation and higher quality.
- Airtight panels connection, all sides of panels have PVC gasket foamed in place to assure airtight and secure fitting; any other sealing between panels on site is eliminated.
- Defrosting through heated gas with re-evaporation of defrosting water permits to reduce the total power installed, shorten defrosting time and limit the warming of the cold room. Dedicated drain hole is not needed.
- Refrigeration unit mounted on a modular panel for easy installation and quick set-up of the cold room. All the refrigeration units are tropicalized (+43°C) and use R452 refrigerant and are supplied with a high/low temperature alarm.
- Right-hinged door is available as standard (left-hinged door on request) and constructed with smooth rounded profiles, cam-lift action hinges, airtight magnetic gasket and high insulation thus allowing to reduce energy and operating costs.
- Newly designed handle complete with lock and interior safety release to prevent entrapment when the door is accidentally locked from outside.
- Temperature controller with touch panel.

Construction

- Panels are clad inside and outside with anti-scratch galvanized plastified steel with 120 micron nontoxic pvc coating, polyurethane foam insulation, CFC and HCFC free.
- Whenever the cold room door is opened the microswitch switches on automatically the internal light and turns off the cooling fan.

Optional Accessories

APPROVAL: _____

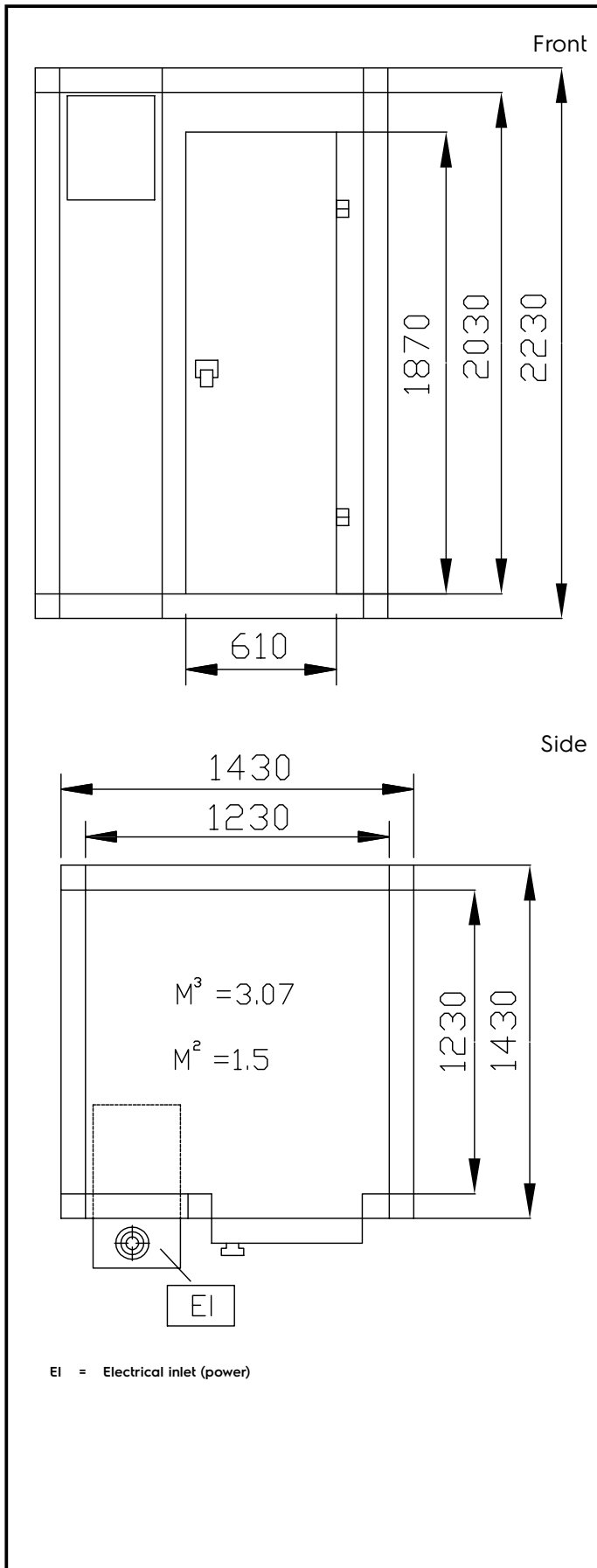

Electric

Supply voltage:

102029 (CR12F031S)

220-230 V/1N ph/50 Hz

Total Watts:

1.15 kW

Key Information:

External dimensions, Width: 1430 mm

External dimensions, Depth: 1430 mm

External dimensions, Height: 2230 mm

Net weight: 350 kg

Refrigeration Data

Compressor power:

1 hp